

SSF082.00L

Lavoce

8" SUBWOOFER

FERRITE MAGNET
STEEL BASKET DRIVER



- 2 INCH CCAW VOICE COIL
- 88 dB/SPL SENSITIVITY
- 700 WATT PROGRAM POWER HANDLING
- LONG THROW DESIGN
- 29,4 mm (1.1 INCH) PEAK TO PEAK MAXIMUM EXCURSION
- FEM OPTIMIZED MOTOR AND SUSPENSIONS
- RESONANCE FREE AND HEAVY DUTY BASKET DESIGN
- OPTIMIZED COOLING SYSTEM
- RUBBER SURROUND MATERIAL
- ALTERNATIVE IMPEDANCE: 4 OHM

GENERAL SPECIFICATIONS

Nominal diameter	mm (in.)	200 (8)
Nominal impedance	Ω	8
Minimum impedance	Ω	6,6
Program power (1)	W	700
AES Power rating (2)	W	350
Sensitivity (3)	dB	88
Frequency range	Hz	50 ÷ 500
Voice coil diameter	mm (in.)	51 (2)
Chassis material		Steel
Magnet material		Ferrite
Magnet dimensions	mm	140 x 62 x 20
OD x ID x h	(in.)	(5.51 x 2.44 x 0.79)
Coil material		CCAW
Former material		Glass Fiber
Cone material		Water Resistant Treated Paper
Surround material		Rubber
Xmax (4)	mm (in.)	9,2 (0.36)
Xmech (5)	mm (in.)	14,7 (0.58)
Gap height	mm (in.)	10 (0.39)
Voice coil winding height	mm (in.)	23,5 (0.92)
Driver displacement volume	l (ft ³)	1 (0.04)
Recommended enclosure	l (ft ³)	25,5 (0.90)
Recommended tuning	Hz	60

SMALL SIGNAL PARAMETERS

DC resistance	Re	Ohm	5,2
Resonance frequency	Fs	Hz	52
Moving mass	Mms	g (oz)	66,3 (2.34)
Compliance	Cms	mm/N	0,144
Force factor	BxL	N/A	14,67
Mechanical Q-factor	Qms		9,94
Electrical Q-factor	Qes		0,52
Total Q-factor	Qts		0,49
Equivalent air volume	Vas	l (ft ³)	9,84 (0.35)
Voice coil Inductance	Le	mH	2,51
Diaphragm area	Sd	cm ² (in. ²)	220 (34.1)
Reference efficiency	Eta 0	%	0,25
Efficiency bandwidth product	EBP	Hz	100

SHIPPING INFORMATION

Net weight	kg (lb.)	4,1 (9)
Multipack size (1)	mm	267 x 267 x 170
W x D x H	(in.)	(10.5 x 10.5 x 6.7)
Multipack weight	kg (lb.)	4,6 (10.1)

FREQUENCY RESPONSE AND IMPEDANCE

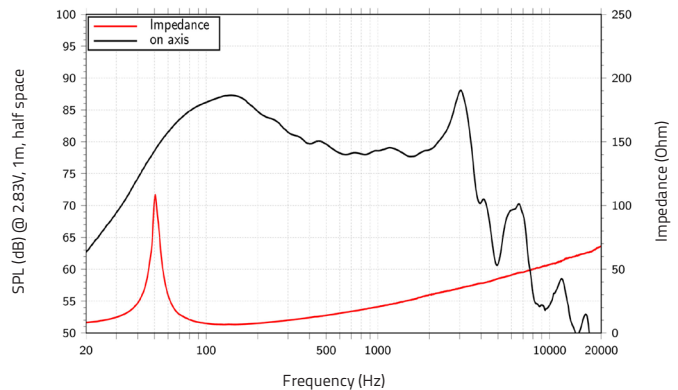

DIMENSIONS mm (in.)

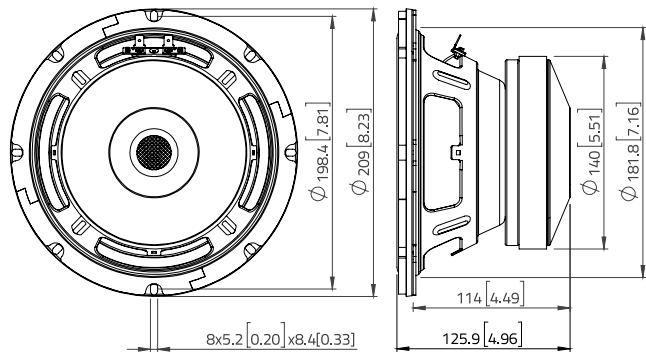

(1) Program power is defined as 3 dB greater than AES Power. (2) Tested for two hours using a continuous, band-limited pink noise signal as per AES 2-1984 Rev. 2003. Loudspeaker tested in free air. (3) From T/S parameters, measured with Klippel DA LPM module. (4) The Xmax is calculated as: $(Hvc - Hg)/2 + Hg/4$. Hvc is the voice coil height and Hg the gap height. (5) The Xmech is calculated as: $(Hvc - Hg)/2 + (Hg - 2)$. Hvc is the voice coil height and Hg the gap height. (6) Thiele-Small parameters are measured after preconditioning: a) at 20°C - 22°C, 50% humidity for 2 hours; b) by Klippel LSI measurement.

All specifications subject to change without notice_H.a

